

NWT-G02-003-002

This document has been written in line with the requirements of the RAPID Gate 2 Guidance and to comply with the regulatory process pursuant to United Utilities' statutory duties. The information presented relates to material or data which is still in the course of completion. Should the solution presented in this document be taken forward, United Utilities will be subject to the statutory duties pursuant to the necessary consenting process, including environmental assessment and consultation as required. This document should be read with those duties in mind.

North West Transfer SRO Vyrnwy Aqueduct (VA) - Conceptual Design Report Gate 2 Submission

14 November 2022

Version NWT-G02-003-002

Contents

1. Executive Summary	4
2. Introduction.....	6
2.2 Background	6
2.3 Vyrnwy Aqueduct SRO Gate 1 Conceptual Design Report.....	7
2.4 Interaction with other SROs.....	7
3. The Vyrnwy Aqueduct System	9
3.2 History of the Vyrnwy Aqueduct.....	9
3.3 Raw Water Aqueduct – Lake Vyrnwy to Oswestry	10
3.4 Treated Water Aqueduct – Oswestry WTW to Prescot WTW	11
3.5 Break Pressure Tanks	12
3.6 Valve Houses	14
3.7 Valve Chambers	16
3.8 Pumping Station.....	17
3.9 Bulk Supply Points.....	18
3.10 Concessionary Supply Points.....	18
3.11 Aqueduct Sections	19
3.12 Oswestry WTW.....	24
3.13 Huntington WTW and the Dee Aqueduct	25
4. Requirements and Boundary Conditions.....	27
5. Related Projects.....	29
5.2 The Vyrnwy Cleaning and Lining project.....	29
5.3 Oswestry AMP7 Improvements	30
6. Gate 1 Options for Development	31
6.2 Trade Scenarios.....	31
7. Gate 2 Options Development – Concept Design.....	33
7.1 Option Development Approach	33
7.2 Network Modelling Key Assumptions and Constraints.....	34
7.3 Concept Design	35
7.4 Norton Tower to Oswestry WTW up to 170MI/d (Opportunity)	35
7.5 Norton Tower to Oswestry WTW up to 205MI/d (Full Scope).....	37
7.6 Huntington to Cotebrook (Discounted)	40
7.7 Pumping Station Design	40
7.8 Valve House Pipework Renewal Options	43
7.9 Valve Chamber Pipework Renewal Options	45
7.10 Bulk Supply Points and Concessionary Supplies	46
7.11 Control and Automation (Systems Thinking)	46
7.12 Flow Conditioning	48

7.13	Water Quality Modelling.....	48
7.14	Surge Analysis	50
7.15	Work at Oswestry Water Treatment Works	50
7.16	Summary	57
8.	Water Trading Enabling Works	59
8.1	Vyrnwy Aqueduct Modernisation Programme (cleaning and lining).....	59
8.2	Oswestry WTW.....	63
9.	Constructability Review	64
9.1	Vyrnwy Aqueduct.....	64
9.2	Oswestry WTW.....	66
10.	Risk and Opportunity	68
11.	Environmental Assessment	69
12.	Town & Country Planning Assessment	70
13.	Programme	71
14.	Further Work	72
15.	Conclusion	73
16.	Glossary.....	74

1. Executive Summary

- 1.1.1 For the Gate 2 submission this report describes the option for the Vyrnwy Aqueduct enabling scope required to support a maximum trade of 205MI/d. A separate CDR report (UU sources) has been developed in parallel which describes the sub options to backfill 167MI/d of water also needed to support the trade.
- 1.1.2 At Gate 1, the maximum trade was capped at 180MI/d therefore the solution and hence scope to achieve a 205MI/d trade differs from that developed for Gate 1.
- 1.1.3 The maximum reliable yield from Lake Vyrnwy is confirmed as [redacted] from this a minimum of [redacted] per day is required to continue supply into the Vyrnwy Aqueduct system for customers, and also to ensure the water in the aqueducts is turned over and pipework conditioned. Therefore the maximum water available to trade from Lake Vyrnwy is [redacted]. In order to achieve 205MI/d, additional water is required [redacted] to supplement the trade, this water shall be pumped to [redacted] utilising lines 1 and 2, with flow continuing down line 3 to supply customers. This represents a significant step change in scope and hence capital cost. This CDR therefore focuses on these two trade flows, such that the additional scope and cost from the Gate 1 option can be evaluated. However, as the 205MI/d trade flow is the only option promoted in the Gate 2 submission, the 170MI/d is included for information and as a comparison to the Gate 1 scope only.
- 1.1.4 To make up a 205MI/d trade, this figure includes a transfer of 25MI/d [redacted] to the Severn Trent region, this allows for a 25MI/d reduction in abstraction from the River Severn [redacted] of which will form part of the transfer. The scope required to transfer 25MI/d to Severn Trent is part of an STT SRO which is not covered in this report.
- 1.1.5 A maximum discharge of 25MI/d is allowed from the Lake direct into the River Vyrnwy, all other trade flows are made up from a combination of partially treated and fully treated (potable) water from Oswestry WTW and the Dee Aqueduct system.

Figure 1 – Solution Scope overview

- 1.1.6 As water is traded out of the Vyrnwy system, water is backfilled by using supply [redacted] and reversing flow back up the aqueduct between Norton Tower and Oswestry WTW [redacted]. A total of three new pumping stations are required.

- 1.1.7 A network model has been developed to support the solution, identify the flow requirements and locations for the proposed pumping stations and establish a high level control philosophy. This has formed the basis of the conceptual design.
- 1.1.8 The new River Vyrnwy bypass pipe required to transfer the trade flows from Oswestry WTW to the River is detailed in a separate CDR report as part of a STT SRO and is not included in this document.
- 1.1.9
- 1.1.10 The capital and operational costs associated with this option are presented in the associated NWT cost report

2. Introduction

2.1.1 This report builds on work completed for the Vyrnwy Aqueduct Strategic Resource Options Report submitted at Gate 1 in June 21. It presents information gathered on the existing system, the key requirements, and constraints that the project must meet, the engineering work undertaken and the scope necessary to meet the various trading scenarios.

2.2 Background

2.2.1 The National Infrastructure Commission produced a report in 2018 entitled ‘Preparing for a Drier Future, England’s Water Infrastructure Needs’ that concluded the water supply system is already strained and the demand will only rise over the coming decades. The commission predicts that by 2050 an extra 4000 MI/d of water supply and demand reduction is delivered by a combination of leakage reduction, demand side initiatives and water transfers. Ofwat initiated a Strategic Resource Options (SRO) programme to provide at least 1500 MI/d of water to areas of England facing water deficit. The SRO programme includes 17 schemes highlighted in Figure 2 to be funded and assessed during AMP7 to determine a portfolio of projects to be selected and ready for implementation in AMP8.

Figure 2 - National Water Transfer (Strategic Resource Options)



2.2.2 The North West Transfer (NWT) SRO is a combination of UU Sources sub-options set out in the UU Sources CDR (NWT-G02-003-001) and Vyrnwy Aqueduct Enabling Works set out in Vyrnwy Aqueduct CDR. Together these allow for the trading of 205 MI/d. This was formed by the merging of the previous UU Sources and Vyrnwy Aqueduct SROs to provide a holistic approach to delivering a transfer solution from the North West of England.

2.2.3 The NWT SRO aims to provide increased water supply resilience both within the Water Resources West (WRW) region and beyond, including the Water Resources South East (WRSE) region via the proposed Severn to Thames Transfer SRO. The Vyrnwy Aqueduct CDR, in conjunction with the UU Sources CDR

illustrates that the NWT SRO can provide a transfer of up to 205 MI/d through enabling works to the Vyrnwy Aqueduct distribution system and development of new water sources in the North West.

2.2.4 The NWT SRO combines with the Severn Thames Transfer (STT) SRO, which allows water to be transferred to the South East based on using water from Lake Vyrnwy. Under the option, Vyrnwy water is released into the River Vyrnwy / Severn, then abstracted in Gloucestershire and transferred via new infrastructure to the River Thames.

2.2.5

2.2.6 Whilst all the sub-options are required to support the transfers, there are times when they can be used to support resilience in the North West. A lack of correlation between drought conditions in the North West and South East is particularly helpful and means that trading is unlikely to be requested in support of STT during approximately half of droughts affecting the North West. Allowing this indirect type of trading support helped us to reduce the cumulative capacity of options required for trading well below the total trading amount (167 MI/d versus 205 MI/d).

2.2.7 The UUS Full Solution comprises nine preferred sub-options built around three surface water sources and six groundwater sources, which together provides a predicted output capacity of 168MI/d

2.3 Vyrnwy Aqueduct SRO Gate 1 Conceptual Design Report

2.3.1 The initial work undertaken on the Vyrnwy Aqueduct SRO was presented in the Gate 1 Conceptual Design Report, submitted to RAPID (Regulators Alliance for Progressing Infrastructure Development) in June 2021. This was a feasibility study and initial conceptual design to scope out what a potential solution might look like.

2.3.2 The Gate 1 Conceptual Design Report (CDR) identified two high level solutions with a number of sub-options for further development and evaluation at Gate 2. This report describes the work undertaken to develop the options and the scope required for the different trade flows.

2.3.3 The Gate 2 solution has progressed and now utilises aqueducts for reverse flow as they are scheduled to be modernised with a PE structural liner, as opposed to identified at Gate 1. The blending of Dee water with Vyrnwy raw water upstream of Oswestry in a blending tank WTW is longer considered an appropriate solution, Gate 2 solution transfers water to the river as part of the trade.

2.4 Interaction with other SROs

UU Sources

2.4.1 Both the UU Sources and Vyrnwy Aqueduct enabling works form the NWT SRO. The UU Sources Construction Design Report is being developed in parallel and does not form part of this report. For further information, please refer to the separate UU Sources CDR document.

River Vyrnwy Bypass Pipeline

2.4.2 An important scope item that affects this project, but is not covered by the NWT SRO, is the River Vyrnwy Bypass Pipeline running from Oswestry WTW to River Severn. This is part of the STT SRO. The pipeline is being designed by Severn Trent Water to receive the full trade flow. It will receive a mixture of raw water, dechlorinated potable water and start up to waste water

Shrewsbury redeployment

- 2.4.3 An important scope item that affects this project but is not covered by the NWT SRO. This element is addressed as part of the STT SRO, it involves increasing the capacity of the Shrewsbury supply from Oswestry WTW from its current maximum flow of 16MI/d to 25MI/d. This allows WTW to reduce abstraction from the River Severn by 25MI/d, this reduced abstraction is the redeployed to take the transfer from 180MI/d to a maximum of 205MI/d.

Raw Water Aqueduct

- 2.4.4 Not part of the NWT SRO, but identified as a risk to UU and will be addressed in UUs PR24 review.
- 2.4.5 There are other SRO UU projects (non SRO) that are related to or impact this project, please refer to Section 5 of this report for specific details.

3. The Vyrnwy Aqueduct System

3.1.1 In order to develop options for the Vyrnwy Aqueduct element of the NWT SRO it is necessary to understand the existing VA System and how it operates. This section describes the historical development and the main features of the current system.

3.2 History of the Vyrnwy Aqueduct

3.2.1 The Vyrnwy Aqueduct supplies water to customers in Mid Cheshire, North Cheshire and Liverpool area.

Figure 3 - Existing Vyrnwy Aqueduct System (General Location Plan)

3.2.2

3.2.3

3.2.4

3.2.5

3.3 Raw Water Aqueduct

3.3.1

3.3.2

3.3.3

3.3.4

3.3.5 A programme of studies on the raw water system is in United Utilities Long Term Asset Management Programme which is not part of the North West Transfer – Vyrnwy Aqueduct SRO scope

Figure 5 -

3.4 Treated Water Aqueduct

3.4.1

3.4.2

3.4.3

3.4.4

Table 1 – Summary of pipe diameters, material, length, and year commissioned.

3.4.5 In addition to the three pipelines, the aqueduct consists of other features along the route that together form the system as follows:

- Break Pressure Tanks
- Valve Houses (incorporating original burst isolation valves)
- Valve Chambers (incorporating cross connection pipework)
- Pumping Stations
- Bulk Supply Points
- Concessionary Supply Points

3.5 Break Pressure Tanks

3.5.1

Table 2 - Break Pressure Tank Volume and key level data

3.5.2 At Malpas BPT there are two tanks, a 1.2MI tank and a 19.1MI tank.

Figure 6 - Malpas Break Pressure Tank

3.5.3 At Cotebrook there are also two hydraulically linked tanks, each with a volume of 9MI. The tanks are buried concrete structures that were refurbished in AMP6. A

Figure 7 - Cotebrook Break Pressure Tank

3.5.4

Figure 8 - Norton Tower

Figure 9 – Norton Tower Site

3.6 Valve Houses

- 3.6.1 There are several Valve Houses located along the aqueduct. The Valve Houses are large ornate brick buildings to house self-acting mechanically operated burst control valves.

The burst control valves on each line were designed to close and isolate in the event of a burst on the aqueduct.

Figure 10 – Typical Valve House building

3.6.2 On either side of the Valve Houses there are usually a set of isolation valves on together with cross connection pipework linking all three lines. The cross connections are used in the event of a section of aqueduct having to be isolated for burst maintenance or repair. There are also air valves or washout valves to enable sections of the aqueduct to be drained down – dependent on whether Valve Houses are at high or low points in the system.

3.6.3 A typical arrangement of a valve house is shown below:

Figure 11 - Typical Valve House Arrangement

- 3.6.4 An unusual feature of the isolation valves on line one is the use of 'jumbo' valves or triple valves. These are early isolation valves manufactured before the technology existed to make large diameter valve castings. Instead, they make use of three smaller valves, or a single casting with three valve gate elements.

3.7 Valve Chambers

- 3.7.1 There are existing Valve Chambers along the route. The Valve Chambers serve as intermediate isolation points between Valve Houses along the aqueduct. They are located in agricultural land and all the valves and ancillary equipment are buried below ground level with the access covers placed at ground level. The valve chambers also include cross connection pipework either side of the isolation valves to enable flows to be transferred from line to line for isolation purposes. All the valves at these chamber locations are manually operated and do not have any power or telemetry.
- 3.7.2 The close proximity and short distances between each line means that the crossover pipework is positioned above the aqueduct pipelines and is quite shallow. All valves on both upstream and downstream crossovers are valved shut during normal operation.
- 3.7.3 A drawing of a typical Valve Chamber is shown below:

Figure 12 - Typical Valve Chamber

3.8

3.8.1

3.8.2

Figure 13 -

3.9 Bulk Supply Points

- 3.9.1 There are several Bulk Supply Points (BSP) along the length of the aqueduct. These provide flow to local supply zones, reservoirs or large customers. The Bulk Supply Points can be connected to any or all of the aqueduct lines and are usually fitted with line valves at the take-off points to enable either isolation, or selection of which line to feed from.

Figure 14 - Typical Bulk Supply Point (BSP)

3.10 Concessionary Supply Points

- 3.10.1 Concessionary Supply points are smaller diameter pipework connected directly to the aqueduct or via existing air valves. These either supply single properties, farms or cattle troughs. They are usually located where there is no local distribution network (i.e., Dwr Cymru – Welsh Water or Severn Trent

Water) and were negotiated when the aqueduct was constructed. The location of the Concessionary Supply points will be discussed in detail later in this document.

Figure 15 -

3.11

3.11.1

3.11.2

3.11.3

3.11.4

4. Requirements and Boundary Conditions

- 4.1.1 The Severn Thames Transfer project is a joint collaboration project between UU, Severn Trent and Thames Water to transfer water from sources in the North West to the River Severn then onwards to the river Thames for use in the south east, potentially commencing 2040.
- 4.1.2 In addition to supporting the STT SRO, UU's WRMP24 and draft Water Resources West Regional Plan recognise that the new water resources and infrastructure to be delivered via NWT would also provide the opportunity to support a wider range of customers. Severn Trent has expressed interest in receiving a transfer of 75MI/d from 2031, the circumstances and duration of trading in this scenario have not yet been defined.
- 4.1.3 The key elements of the SRO requirements applicable to VA Water Trading SRO are presented below:
 - (1) Complete the concept design of the North West Transfer solution to ensure UU can maintain supply resilience and levels of service to all customers fed off the VA while trading up to 205 MI/d of water from the Vyrnwy system for up to 15% of the time over a long-term average (maximum continuous trade duration of 180 days).
 - (2) Vyrnwy Aqueduct Enabling Works (VA) which will require the ability to support water trading whilst also maintaining supplies for customers
 - (3) The agreed NWT transfer volumes are required up to a maximum of 205 MI/d
- 4.1.4 In addition, the following Constraints apply to the option:
 - (1) Lake Vyrnwy sustainable yield is as agreed in the Water Resources Steering Group.
 - (2) The stated maximum release from Vyrnwy dam into the River Vyrnwy is 25 MI/d. Note that this is a recent reduction from 75MI/d identified in version 0 of the Requirements Statement (28th March 2022).
 - (3)
 - (4)
 - (5)
 - (6)

(7)

See Figure 24 on page 38 which identifies the key scope items included in this SRO.

5. Related Projects

5.1.1 There are two projects being delivered that have significant impacts on the VA Water Trading scheme. These are the VA Cleaning and Lining Project and the Oswestry WTW AMP7 Improvements project. The projects are described below:

5.2 The Vyrnwy Cleaning and Lining project

5.2.1 The Vyrnwy Cleaning and Lining Project is a project to clean and line the Vyrnwy Aqueduct pipelines

5.2.2 The key information from the Requirements Statement has been extracted below:

Requirements:

-
- Requirement 1 must be delivered in line with point 3(b)(v) in the Enforcement Order, which states that the cleaning/lining work must be **completed by 31 December 2028**.

5.2.3 The timing of the Vyrnwy Cleaning and Lining project offers both problems and opportunities to the Vyrnwy Aqueduct Water Trading scheme.

5.2.4 The Cleaning and Lining work is scheduled to be undertaken in three separate contracts. The first contract - is in the procurement phase and anticipated to start in Q1 2023. The second and third phases are still in development and are expected to be tendered in 2023, all with a view to completion before December 2028.

5.2.5 Given the significant interfaces between the VA Cleaning and Lining and VA Water Trading projects, there are a number of important issues to be considered:

- (1)
- (2) The Cleaning and Lining project is not replacing any of the crossover pipework or valve house pipework and this will fall under the VA Water Trading scope. It has been demonstrated that the small sections which remain unlined do not pose a water quality risk.
- (3) The two projects involve major work on the same asset and therefore affect the same third parties and landowners. Completion of the work for the two schemes could take somewhere between 6-10 years. Minimising the impact on landowners and third parties across the two projects is therefore an important consideration.
- (4) Timing of the projects is also a significant issue. The Cleaning and Lining project has an enforcement date by which the work must be completed. While it is important to combine the work as much as possible, it must not impact on the Cleaning and Lining project

achieving the December 2028 date. It is important that scope delivered for the Cleaning and Lining project does not impair the ability to engineer the VA Water Trading project.

- (5) To deliver the work, both projects will require individual line outages on the aqueduct, these will need to be co-ordinated

5.3

5.3.1

5.3.2

5.3.3

6. Gate 1 Options for Development

6.1.1 The Conceptual Design Report at Gate 1 identified two main options for meeting the Vyrnwy Aqueduct SRO for development through to Gate 2. These were as follows:

- Option A –
- Option B –

6.1.2

6.1.3

6.1.4

Figure 22 - Options from Gate 1 Submission

6.2 Trade Scenarios

6.2.1 At **Gate 1**, five incremental trade flow scenarios were identified ranging from $\leq 50\text{MI/d}$ up to 180MI/d , each with different implications for the level of engineering required.

- 6.2.2 In addition, after Gate 1, the team were asked to consider a sixth trade scenario for flows up to 205MI/d.
- 6.2.3 The trade flow scenarios assumed that up to 75MI/d(since reduced to 25MI/d for Gate 2 due to environmental constraints imposed by the EA) can be released directly into the River Vyrnwy from Lake Vyrnwy
- 6.2.4 These trade flow scenarios are described in Table 7 below:

Note that Gate 2 flows/constraints differ from those used at Gate 1, see section 3.

Note that Figure 22 is included only to demonstrate options presented at Gate 1 submission and is now superseded

Table 7 - Gate 1 Water Transfer Volumes Description

Transfer Volume (MI/d)	Description
0-50	
51-75	
76-135	
136-150	
151-180	
181-205	

*Note, pilot trials were to be carried out during Gate 2 for the blending solution, but option has since been discounted

7. Gate 2 Options Development – Concept Design

7.1 Option Development Approach

- 7.1.1 The approach used to develop the options involved a combination of data gathering on the existing system, network modelling of options and holding a series of workshops with key stakeholders as the work progressed. The engineering scope for the modelled solutions was then developed in greater detail and Estimating Briefs prepared.
- 7.1.2 The data gathering phase collected existing information about the aqueduct from within UU record systems together with site visits and meetings/workshops held with Operations staff, to understand how the system currently operates and identify any issues and operational constraints.
- 7.1.3 Network modelling was used as the main basis for identifying and developing solutions. United Utilities' network modelling team undertook detailed analysis of the different trading scenarios to develop the scope required for each option. The findings from the modelling were discussed at the stakeholder workshops enabling the solutions to be further developed.
- 7.1.4 After the high-level options were agreed, surge analysis studies were undertaken to identify any surge management scope to be included. The Civil, Mechanical and Electrical engineering work was then developed conceptual design scope was then prepared and Estimating Briefs prepared.
- 7.1.5 The concept design is summarised in this report, schematic diagrams, scope documents and estimating briefs.

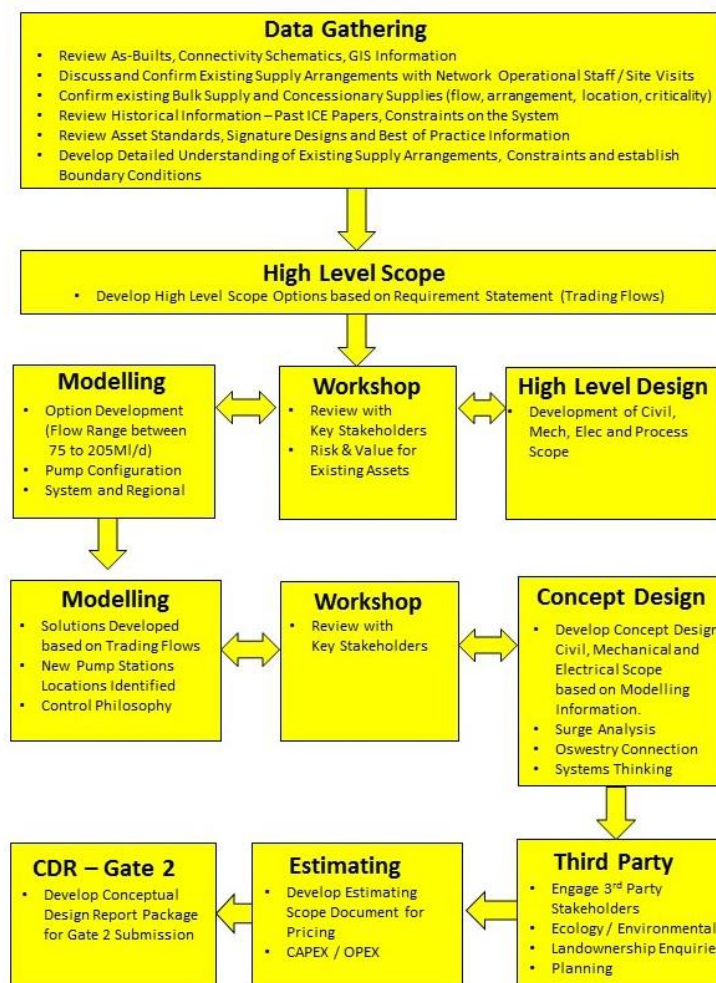

7.2 Network Modelling Key Assumptions and Constraints

7.2.1 The key assumptions made for the development of the network model are described in the section below.

Vyrnwy Aqueduct

- All existing crossover and isolation points will be replaced / replicated.
- Planning permission will be achievable for any buildings, accesses, pipelines etc. not covered by permitted development rights
- The existing valves will be replaced with flow control valves
- The existing break pressure tanks can provide sufficient control band levels from which to operate and control the new pumping stations when reversing flow
- The relining work will use PE liner pipes that are suitable for the pumping / pressure requirements of the VA Water Trading project.
- Slip lining works on the steel pipe of lengths up to 900m is achievable for section A
- Signature design pumping stations have been assumed for concept design phase
- Requirements for surge protection have been determined at concept design phase based on UU Asset Standards
-
- Facilities will be provided to enable significant remote monitoring and control (otherwise known as Systems Thinking), the full scope of which will be developed in later phases of work.

River Vyrnwy Bypass pipework

- Discharge consent can be obtained for the flow and Water Quality Parameters (de-chlorinated water)
- Raw water pipeline will be designed to take the full aqueduct flow for all trade options.

Constraints

- For work on the treated section of the VA, only one line can be taken out of service and exposed at any time.
- Double isolation outages on single aqueduct lines are an acceptable default.
- VA Water Trading work must not prevent the Cleaning and Lining project from meeting its delivery deadline
- WTW must be operational throughout Water Trading.
- The Aqueduct will require continuous Flow Conditioning so that it can be reversed at short notice.

7.3 Concept Design

7.3.1 The following sections of this report describe the options and the main engineering scope required to deliver them. The transfer options considered are as follows:

- up to 170 MI/d (this has been considered and presented as an opportunity option)
- up to 205 MI/d (Full scope option)
- (Discounted option)

7.3.2 The report also considers the impact of the project at Oswestry WTW and the engineering required for the different trade options.

7.4 170MI/d (Opportunity)

7.4.1 This option deals with all trade flows up to 170MI/d. It involves putting trade flows into the River Vyrnwy via a combination of releasing flows directly into the river at the Lake Vyrnwy dam and via a new pipeline to the river. The option is shown diagrammatically below:

Figure 23 - Proposed Vyrnwy SRO – Transfer Volume up to 170 MI/d

7.4.2

7.4.3

7.4.4

7.4.5

7.4.6

7.4.7 The main scope items required for this solution are described in the table below:

Table 8 - 170MI/d Transfer Scope

7.5

205MI/d (Full Scope)

- 7.5.1 This option deals with all trade flows up to 205MI/d. It involves putting trade flows into the River Vyrnwy via a combination of releasing flows directly into the river at the Lake Vyrnwy dam and via a new pipeline from WTW to the river. However, to get to 205MI/d, an additional 25MI/d of potable water has to be provided from regional sources via the Vyrnwy Aqueduct and is then supplied to the

Severn Trent Water plant. This allows a reduction in abstraction of 25MI/d from the River Severn which takes the trade flow to 205MI/d. The option is shown diagrammatically below:

Figure 24 - Proposed Vyrnwy SRO – Transfer Volume up to 205 MI/d

7.5.2

7.5.3

7.5.4

7.5.5

7.5.6

7.5.7

7.5.8

7.5.9

7.5.10 The main scope items required for this solution are described in the table below:

Table 9 - 205MI/d Transfer Scope

7.6 Huntington to Cotebrook (Discounted)

- 7.6.1 This option involves constructing a new pipeline from Huntington WTW at Chester to Cotebrook Break Pressure Tank. The solution puts water into the Vyrnwy Aqueduct network at Cotebrook BPT to supply water downstream of that point. The pipeline would be circa 20km in length and would require a pumping station at Huntington WTW and an intermediate pumping station because of the topography.
- 7.6.2 The modelling team developed the solution and found that it could be discounted for a number of reasons.
- 7.6.3 The solution requires construction of a new asset that would remain out of service for long periods of time. The transfer pipeline would only be required during water trading and the rest of the time would either have to be drained and mothballed, or somehow maintained in use with a constant turnover flow sufficient to keep it sweet.
- 7.6.4 The new pipeline is an expensive asset to achieve an outcome that can be met with the existing assets. The cost of constructing the new pipeline mean that this option will be uneconomic compared to the other alternatives being considered. Cost coupled with the operational issues mean that this option is not a viable solution and has been discounted.

7.7 Pumping Station Design

- 7.7.1 Each pumping station proposed follows the UU signature design 16056 for pumping stations sized 450-900 l/s, with automated valves on the common suction and discharge lines.
- 7.7.2 Pumps are proposed to operate duty/assist/standby on each line that requires boosting. They are horizontally mounted, side mounted variable speed split casing centrifugal. Each pumping station will be located inside a new building with an overhead travelling crane to service the pumps. If surge vessels are required at the pumping station, these are proposed to be located outside, with the air compressors located inside the pumping station.
- 7.7.3 For surge vessel sizing and bypass arrangements, required for surge, see the separate surge section within this report.

- 7.7.4 Consideration needs to be given to operating the pumps when not in trading mode, as the pipelines would need to be kept sweet and the pumps will need to be rotated regularly.
- 7.7.5 Typical Pumping station from Signature Design 16056 below

Figure 25 - Typical Pumping Station – Signature Design (3D)

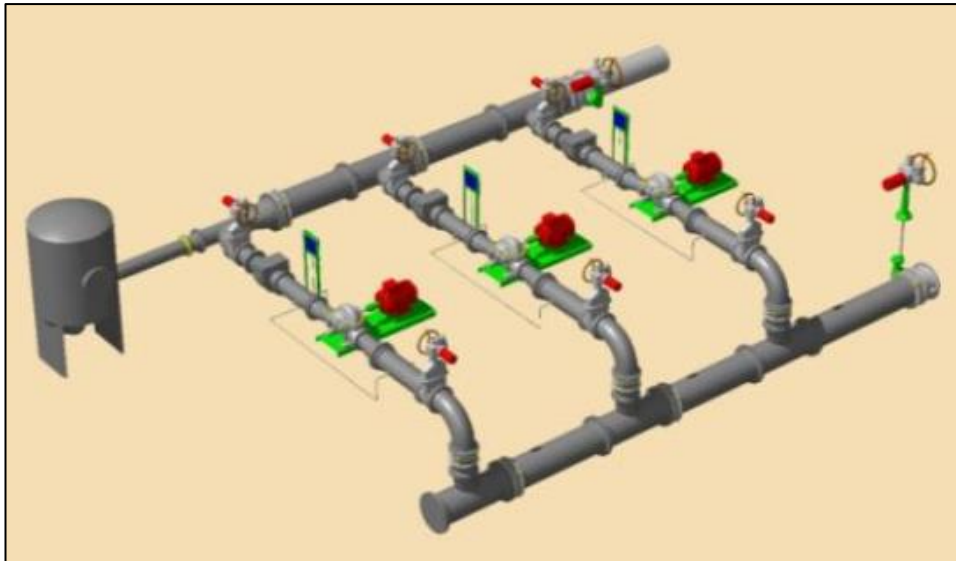
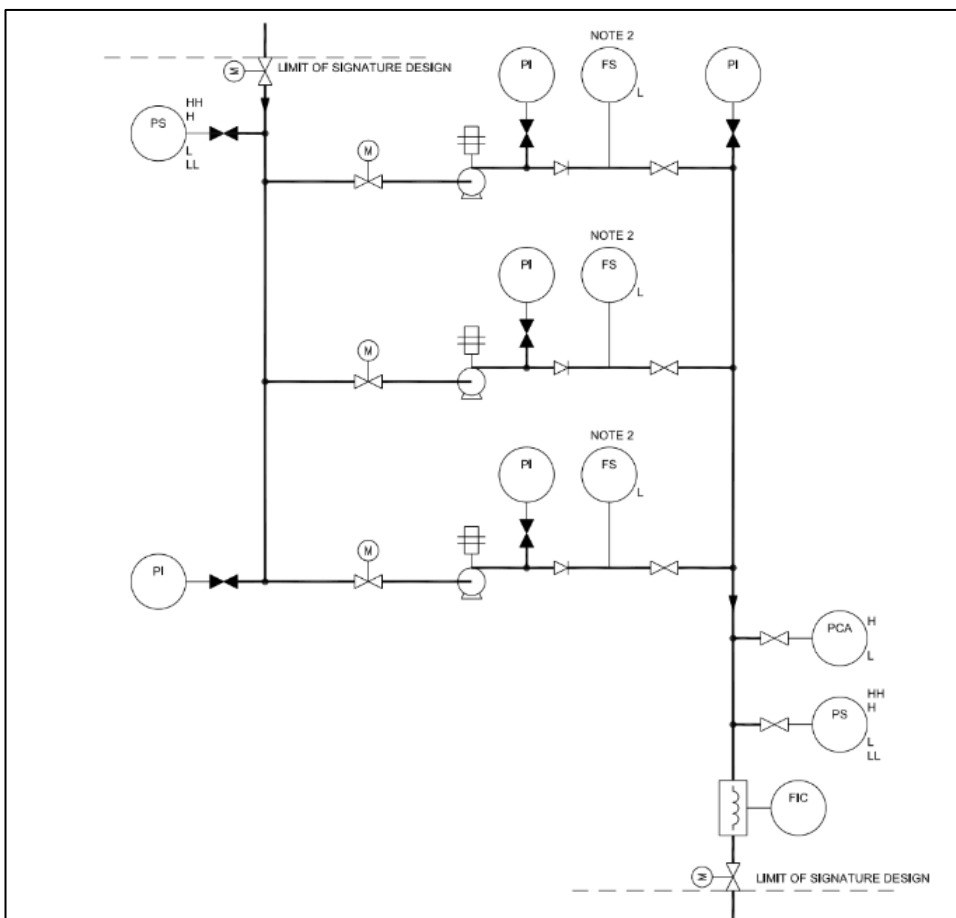

Figure 26 - Typical Pumping Station P&ID



- 7.7.6 Figure 27 and Figure 28 below show a typical arrangement for a proposed new pumping station on lines 1 and 2 and how they would be operated under normal Business as Usual (BAU) flow and under Water Trading conditions.

Figure 27 - Typical Arrangement for Proposed New Pumping Stations - Normal Operation (BAU)

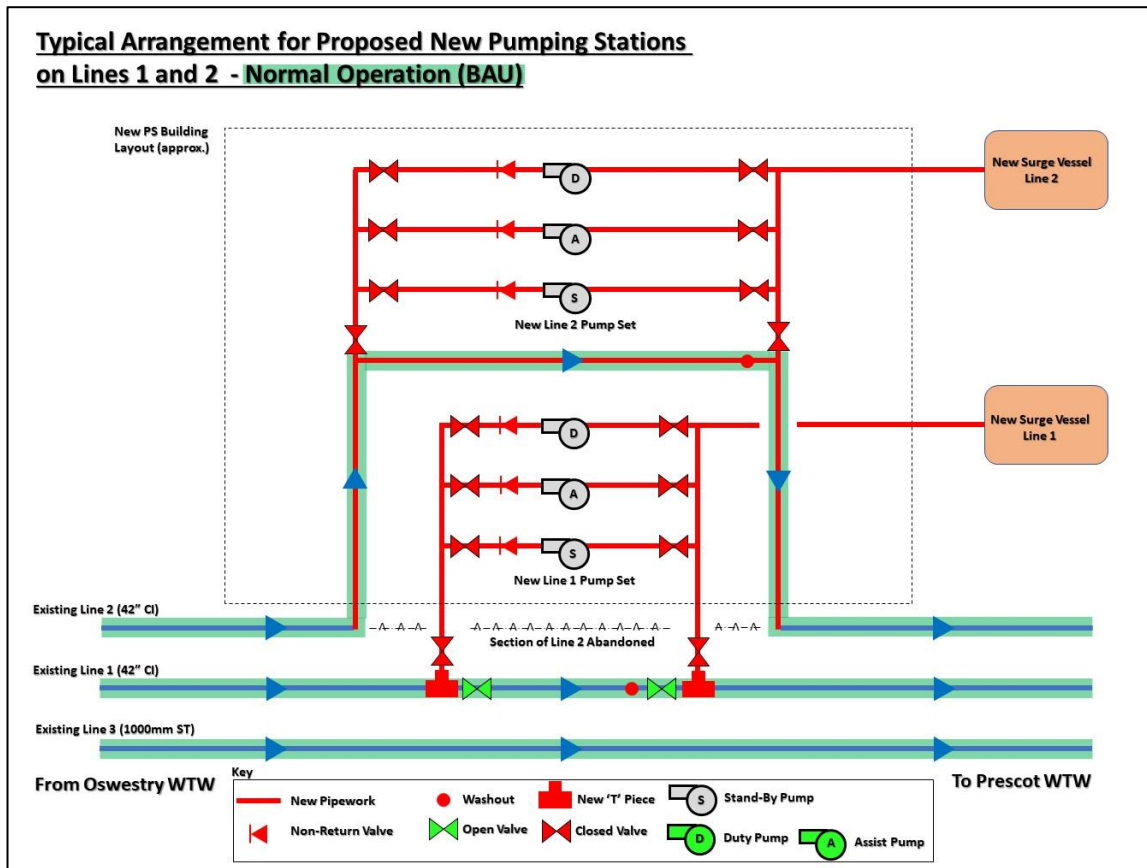
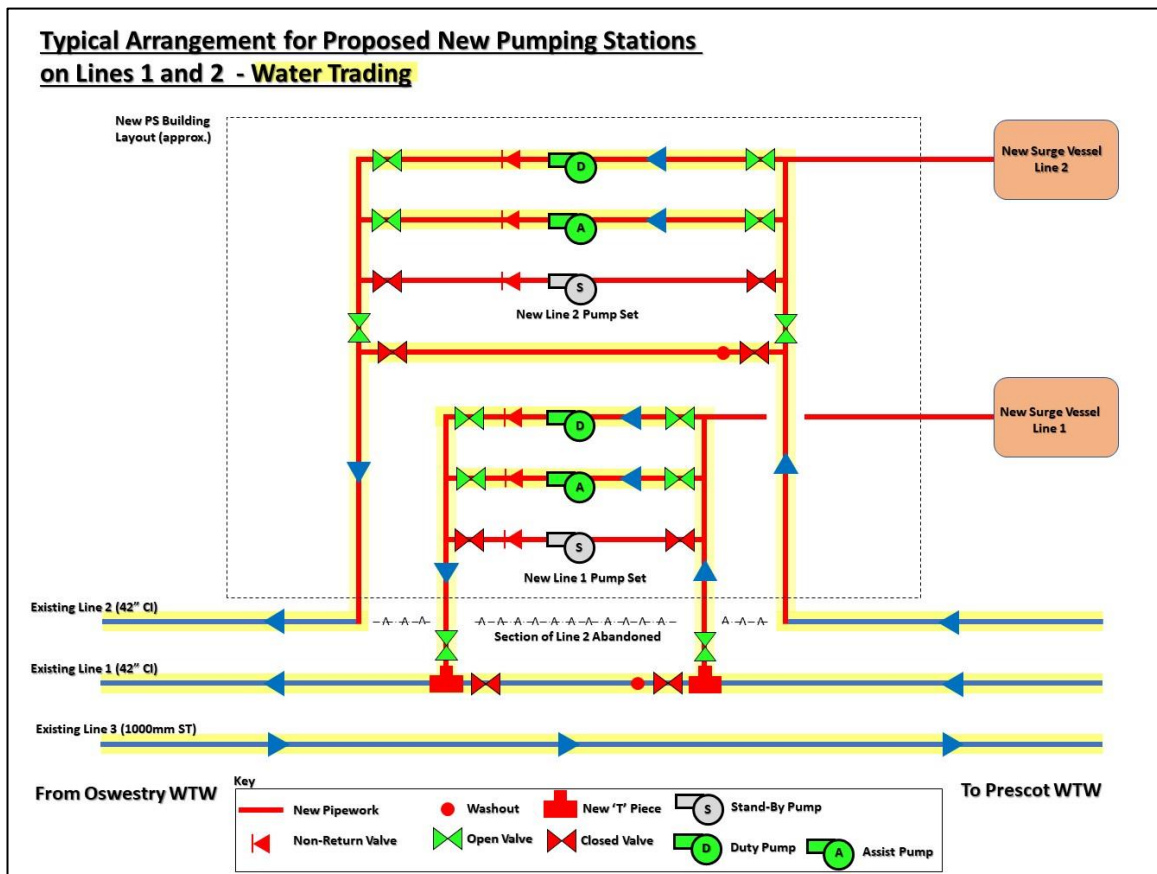

Figure 28 - Typical Arrangement for Proposed New Pumping Stations – Water Trading



7.8 Valve House Pipework Renewal Options

- 7.8.1 The VA Cleaning and Lining project is refurbishing the pipework with the exception of the pipework at Valve Houses and Valve Chambers. This pipework will need renewing to meet the design horizon and pressure requirements for the VA Water Trading project.
- 7.8.2 Three main options were identified for the renewal of the Valve House pipework as follows
- Valve House refurbishment online
 - Build a new Valve House off line
 - Build a bypass and abandon the Valve House
- 7.8.3 The option to be used will be selected on a site-by-site basis. The decision will be influenced by a number of factors including: the ability to get aqueduct outages, third party constraints, land access ownership, hydraulic considerations etc. The actual option to be used at each site will be developed in the next phase of work. The estimating brief states which option has been assumed costed at each site.
- 7.8.4 The sections below describe the options in more detail.

Valve House Refurbishment - Replace Existing Pipework and Valves

- 7.8.5 This option involves retaining the valve house in its existing location and replacing the pipework and valves in situ. The valve house structure would be refurbished. The sketches below indicate how this work might be undertaken in stages whilst keeping the aqueduct live.

Figure 29 - Valve House Refurbishment Part 1

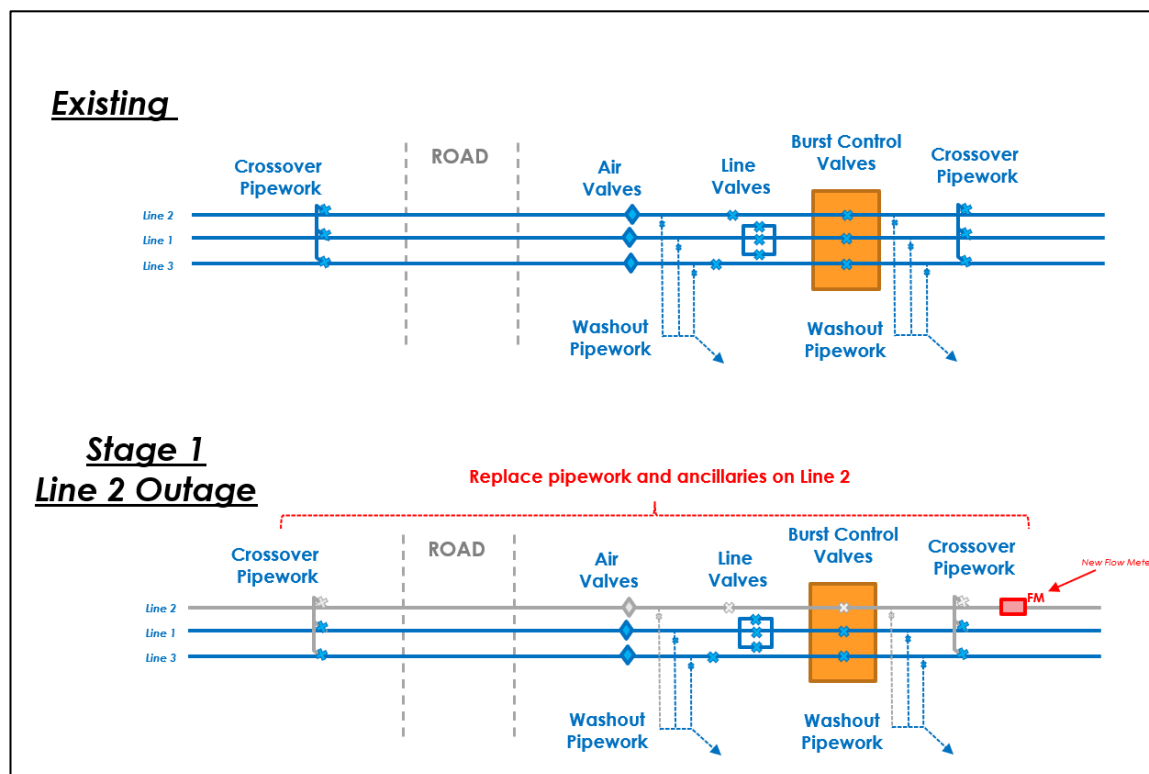
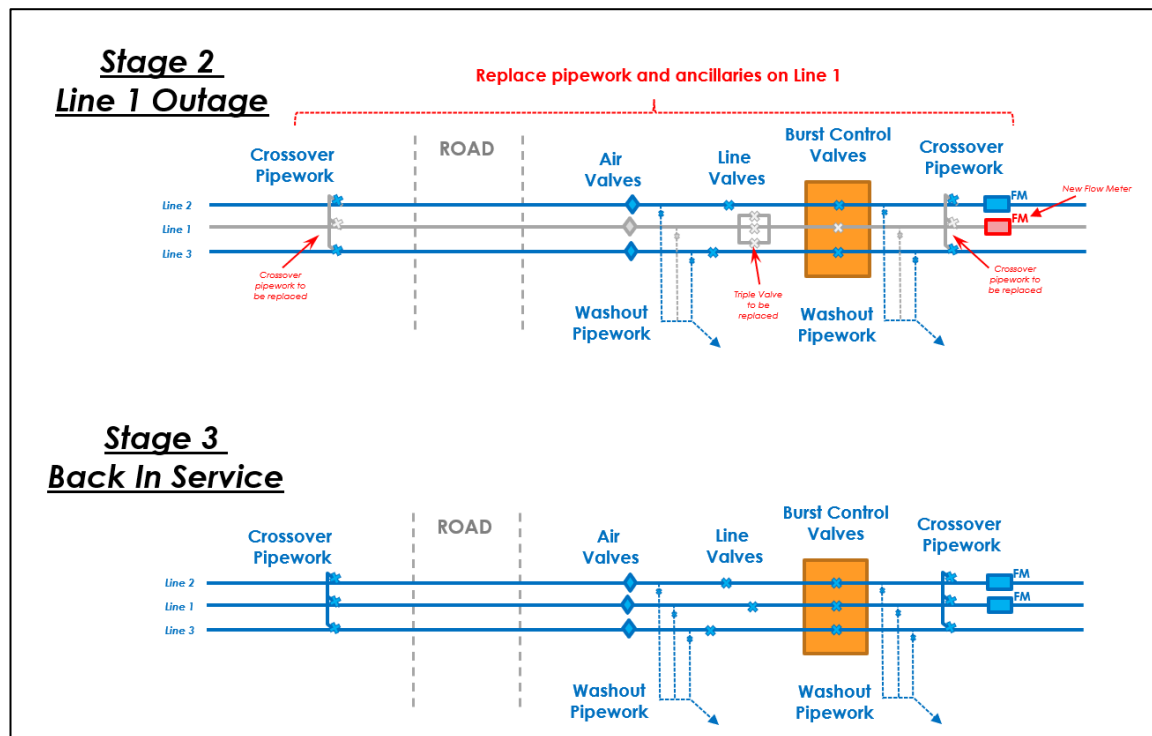

Figure 30 - Valve House Refurbishment Part 2



7.8.6 This option minimizes the hydraulic impacts of the refurbishment and retains the valve house in its existing location. It uses existing easements, keeping pipe routes in the same location. However, replacing pipework online is more complex. It involves working adjacent to live aqueduct lines meaning work will likely be slow to avoid damage or disturbance.

Build New Valve House Off Line

7.8.7 This option involves building a new Valve House in a nearby location off line. The valve house would then be connected to the aqueduct line by line in a staged approach to commissioning. The sketches below indicate how this work might be undertaken whilst keeping the aqueduct live.

Figure 31 - Build New Valve House Off-Line Part 1

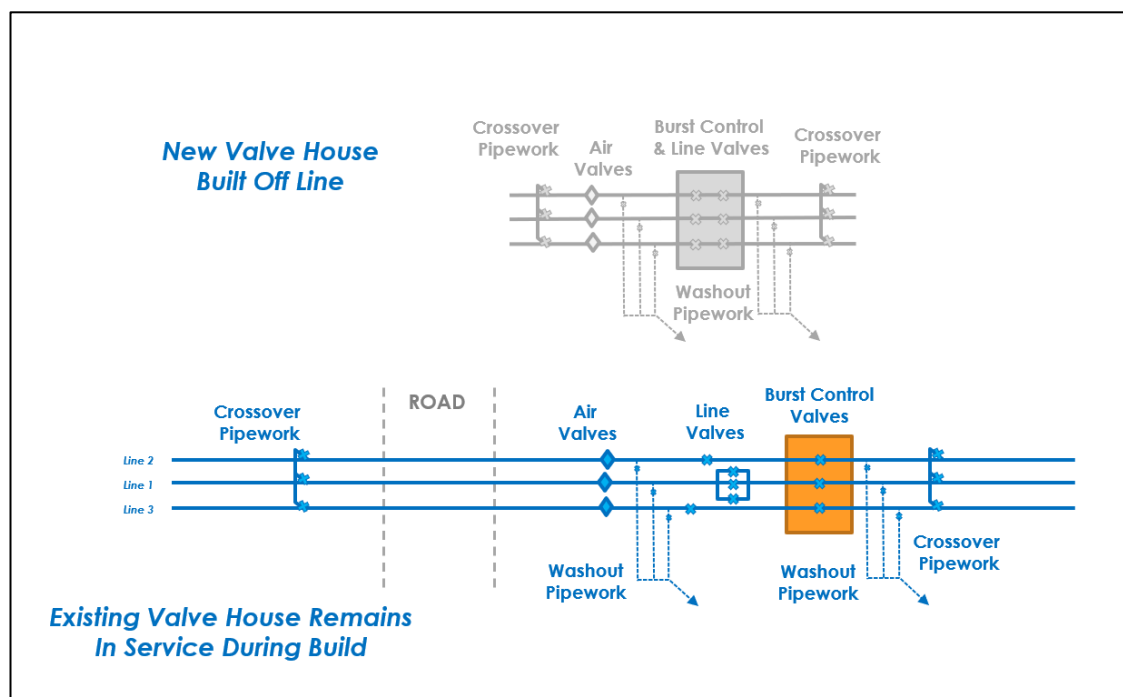
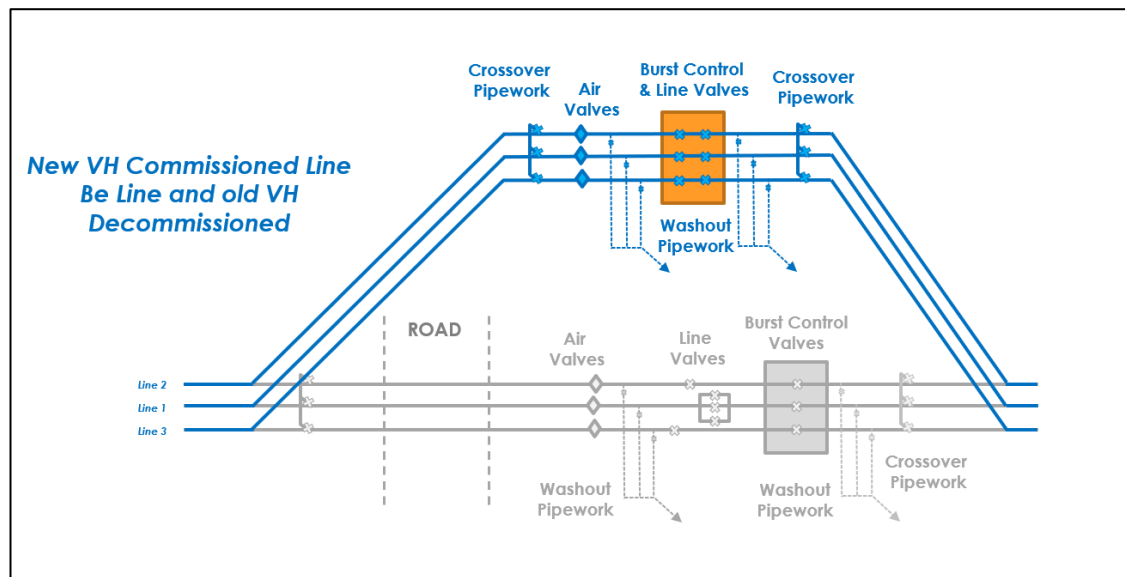

Figure 32 - Build New Valve House Off-Line Part 2



7.8.8 This option minimizes the time spent working adjacent to the live aqueducts and avoids the need for lengthy outages. However, it will require land purchase and planning permission. The hydraulic impact of additional bends would also have to be assessed.

Build Bypass Pipework Around Valve House

7.8.9 This option involves building a new bypass pipeline around the valve house and abandoning it all together. Whilst unlikely to be suitable in most locations, it may be considered because of the proximity of isolation valves and crossover pipework at the adjacent pumping station.

Figure 33 - Build Bypass Pipework Around Valve House

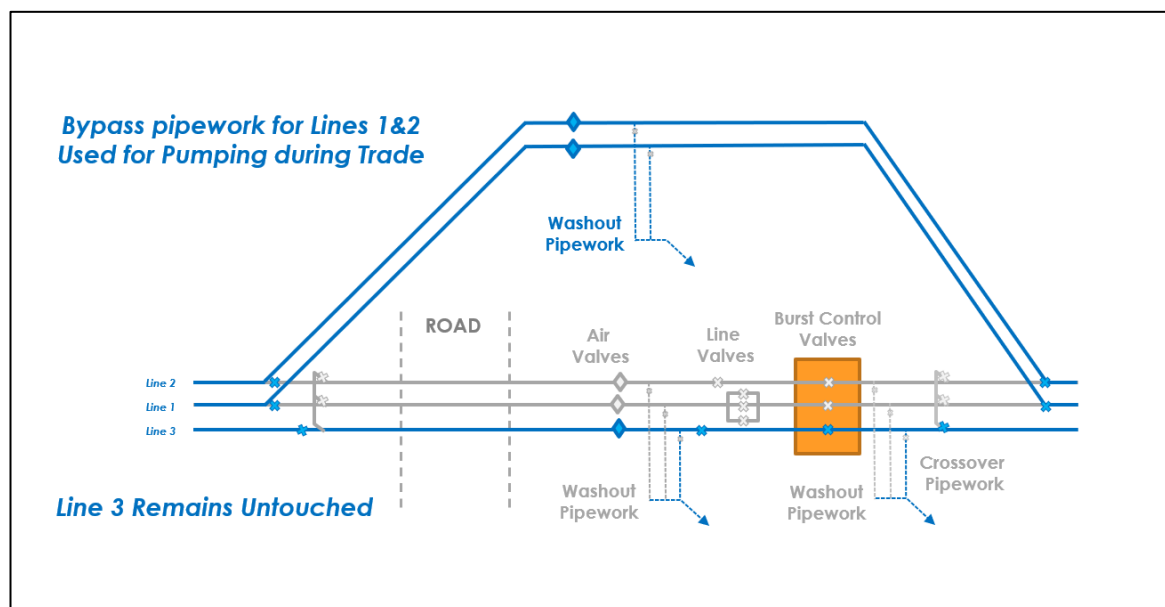

7.8.10 At Bickerton, this option would remove the need to disturb a residential garden / driveway for months on end with major engineering works. The solution will have to be assessed in more detail in the next phase of work when discussions with landowners can start.

7.9 Valve Chamber Pipework Renewal Options

7.9.1 The Valve Chamber pipework renewal options are similar to the Valve House Renewal Options. The Valve Chamber pipework must be renewed to meet the design horizon and pressure requirements for

the VA Water Trading project. In addition to renewing the Valve Chamber pipework, the valves must also be actuated, requiring a power supply, telecommunications and a control kiosk.

Two main options for renewing the Valve Chambers were considered:

- Valve Chamber refurbishment online
- Build a new Valve House off line

7.9.2 The option to be used will be selected on a site-by-site basis. The decision will be influenced by a number of factors including: the ability to get aqueduct outages, third party constraints, land access ownership, hydraulic considerations etc. The actual option to be used at each site will be developed in the next phase of work.

7.9.3 The sections below describe the options in more detail.

Valve Chamber Refurbishment - Replace Existing Pipework and Valves

7.9.4 This option involves replacing the Valve Chamber pipework and valves online in-situ. The valves will need to be located in a position where the headworks can be housed in a kiosk and actuated. As with the Valve House Refurbishment option, only one line will be taken out of service and replaced at a time.

7.9.5 This option minimizes the hydraulic impacts of the refurbishment and retains the Valve Chamber in its existing location. It uses existing easements, keeping pipe routes in the same location. However, replacing pipework online is more complex. It involves working adjacent to live aqueduct lines meaning work will likely be slow to avoid damage or disturbance.

7.9.6 In most locations it is anticipated that this is likely to be the preferred solution.

Build New Valve Chamber Off Line

7.9.7 This option involves building a new Valve Chamber in an adjacent location off line. The Valve Chamber would then be connected to the aqueduct line by line in a staged approach to commissioning in a similar way to the Valve House option above.

7.9.8 This option minimizes the time spent working adjacent to the live aqueducts and avoids the need for lengthy outages. However, it will require land purchase and planning permission. The hydraulic impact of additional bends would also have to be assessed.

7.10 Bulk Supply Points and Concessionary Supplies

7.10.1 The Bulk Supply Points and Concessionary Supply Points are currently fed from various combinations of 1, 2 or three aqueduct lines. In order to provide a suitable level of robustness, they will be connected to all three lines. A valve and manifold arrangement will be provided that will enable bulk supply / concessionary supply to be fed from any or all of the lines as required.

7.10.2 The precise details required at each bulk / concessionary point will be developed in the next phase of work. The current connection arrangement is described in Section 3.11

7.11 Control and Automation (Systems Thinking)

7.11.1 For the Gate 2 concept design a high-level approach has been taken for systems thinking. The approach as set out below will ensure that we are designing the solution in line with the company's System Thinking design principles. This involves a high-level evaluation of how we can support the business ambitions against the 8 Systems Thinking capabilities. Ultimately this will ensure that any technical requirements to meet the capability aspirations have been highlighted and addressed.

7.11.2 The requirements identified in this phase will be developed further as the project moves into the next phase.

- 7.11.3 The requirement is for the project to support the business Systems Thinking maturity level 4 and enable an end-to-end business capability to be realised.
- 7.11.4 An initial assessment of the Vyrnwy aqueduct system has been undertaken to:
- Map the proposed system boundaries.
 - Identify and collate the ST level 4 capability requirements relevant to the Aqueduct System
 - Identify the technology/asset requirements to support the delivery of the ST requirements including aspects such as production planning, predictive maintenance, monitoring & control and data & information insights
 - Map these requirements against the existing infrastructure in the region.
 - Map the requirements against the existing Capital projects in the region
 - Gap analysis of the required technical capability against the existing assets and planned project scope.
 - Identify opportunities for delivery of ST scope on the existing projects. (Changes to specification or additional scope).
 - Identify the gaps to get from level 2 to level 4.

Vyrnwy Aqueduct Automation Initial Requirements

- Manage the volume of water in the Vyrnwy Raw Water Aqueduct
- Enable a flow to the minimum demand within 1 hour following an unplanned shutdown at the works.
- Ability to monitor and maintain levels of the break pressure tanks within existing control levels.
- Remote flow control for normal operation of the aqueduct in conjunction with shutdown provision
- Link the automated control system on the Vyrnwy Aqueduct to the new control system
- Refurbish Boosters and enable pumps 3 & 4 to be remotely operated for boosting flows. Includes standard MCC to replace existing 'unsafe' panel.
- Automated control of all pumping stations for reversing flows during trading, linked and control by operating band levels within the break pressure tanks
- Automated conditioning of aqueducts to ensure minimum timeframe possible for entering in and out of trading scenario
- Water quality monitoring within the VA
- Water quality monitoring and shutdown control within the raw water bypass discharge pipe
- Automatic self-closing valves (for burst isolation)
- Automatic crossover valves
- Automatic BSP control valves to allow continuity of supply during a planned or unplanned shutdown event
- Automated changeover plan and sequencing for entering into a trade scenario
- Automated changeover plan and sequencing for exiting a trade scenario and reverting to gravity flow (Business as usual)

- For actuation and automation there will be a need for new power supplies circa 20kVA and control along with a reliable communications network.
- Network and WTW integrated optimisation and digital twin

7.12 Flow Conditioning

- 7.12.1 The Vyrnwy Aqueduct currently operates in a single direction . The flow rates are relatively stable with gradual increases or decreases being carefully managed by the Aqueduct Controllers. This way of operating helps to manage the risk of turbidity and discoloration by reducing the likelihood of settled silt and particles in the pipelines being disturbed.
- 7.12.2 Under the VA Water Trading scheme, the aqueduct will have flows reversed in lines one and two with water pumped back up. Reversing flows in this way creates higher risk of turbidity and discoloration problems.
- 7.12.3 Another potential issue with the solution is the very low flow rates . The low flow rates increase the risk of silt settling in the pipeline, then causing turbidity issues when higher flows are experienced or when flows are reversed.
- 7.12.4 A further potential risk is that the low flow rates could cause problems with the water age because the turnover is so low.
- 7.12.5 To manage these issues, a regime of flow conditioning in the aqueduct lines will be necessary during water trading and during normal operation. This is to ensure that the aqueduct operation can be switched from normal operation and water trading operation and back again without the risk of facing turbidity and discoloration issues.
- 7.12.6 An important point to note is that for polyethylene (PE) pipelines, flow conditioning only needs to be undertaken in one direction. This is because the smooth internal surface does not trap silt and therefore the high flow rates are effective in preventing silt build-up for bi-directional operation.
- 7.12.7 **Flow Conditioning in Normal Operation** - This involves putting the maximum flow through each of the aqueduct lines for up to an hour each week. This can be achieved by throttling back on two of the lines and forcing more flow down the line to be conditioned. An automated system for controlling this process will have to be developed during the next stage of the design that can take account of water levels in tanks and automatically operate valves to manage the network.
- 7.12.8 **Flow Conditioning in Water Trading Operation** – This involves putting the maximum flow through each of the aqueduct lines for up to an hour each week. For the pumped lines, this will be achieved by pumping at the maximum flow rate through each line to condition the lines. For the gravity sections, the conditioning will be achieved by throttling back on two of the lines and forcing more flow down the line to be conditioned. An automated system for controlling this process will have to be developed during the next stage of the design that can take account of water levels in tanks and automatically operate valves to manage the network.

7.13 Water Quality Modelling

Water Quality Modelling Assessments to be undertaken

- 7.13.1 As part of assessing the impact on water quality as a result of the identified new sources and network configuration changes, blending assessments were undertaken during Gate 1 and 2 phases of the North West Transfer project. The blending results were used to determine predicted levels of water hardness and potential impact on customers following those changes.
- 7.13.2 It was however noted on completion of these phases that further more detailed assessments were needed to allow for better understanding of blending ratios especially variation across typical 24hr

periods. Further discussions were also needed to understand if there was a need to look at different demand scenarios as part of these water quality assessments.

7.13.3 The following activities have been highlighted as key requirements to refining water quality assessments and for determining the hydraulic needs as enablers of the new sources and solutions for the water transfer process.

- Miser runs to understand optimal management and use of sources
- Hydraulic needs assessments following Miser optimisations
- Detailed blending assessments
- Water age analyses
- Chlorine Modelling
- Transition assessments

Miser runs to understand optimal management and use of sources

7.13.4 Miser will focus on water resource utilisation and how best to meet the demand requirements in an optimal way. Different demand horizons will be considered as required for the project. The different tasks for Miser have been considered separately and have therefore not been detailed in this section/document.

Hydraulic needs assessment following Miser optimisations

7.13.5 This task will be completed in Synergi. It will involve understanding how the network can facilitate the distribution of water through the system to enable water trading. Capacity of pipes and how they can serve the system under changed configuration will be assessed against S14 Design of Water Networks standard. If any enabling works are identified, these will be highlighted for consideration and costing

Detailed blending assessments

7.13.6 This task will be completed in Synergi. It will focus on refining the blending assessments for the identified sources. The impact of demand diurnal patterns on blending will be investigated. The results will be discussed with the Engineering Process team as well as Water Quality Regulatory team in order to understand impact on customers and make recommendations on potential mitigations.

Water Age Analyses

7.13.7 This task will be completed in Synergi. It will focus on understanding the impact on water age as a result of any changes proposed in bringing in new sources and to facilitate trading. Water age is a major factor in water quality deterioration in distribution systems. This assessment will help identify areas of higher water age compared to original / normal operation configuration result. Recommendations will be given to mitigate observed results and any other potential risks identified.

Chlorine Modelling

7.13.8 This task will be completed in Synergi. The task will focus on systems with new sources (i.e. sources that do not currently exist or are not in operation) as well as areas where high water age is identified. The assessment process will involve collecting samples for black bottle tests, deploying chlorine monitors, retrieving the monitors, calibrating models for chlorine decay and running scenarios to recommend chlorine dosing (free chlorine levels) and requirements for secondary chlorine disinfection points on the network.

Transition Modelling

7.13.9 This task will be completed predominately in Synergi as well as using tools developed by Sheffield University for understanding discoloration based on PODDS theory. The main aim of this task will be to understand risks involved when the network is configured from its normal operational arrangement to the trading arrangement. Key risks such as pressure changes and potential discoloration will be assessed

and highlighted for mitigation. Any conditioning required to facilitate transition will also be investigated and recommendations on turbidity monitoring made.

Water Quality Modelling Summary

- 7.13.10 In summary, the six factors referenced in items 7.13.3 that affect water quality shall be developed further and completed as part of the detailed design phase for the Gate 3 submission. They are key to understanding and mitigating the potential impact to Customer's water.

7.14 Surge Analysis

- 7.14.1 A surge analysis has been undertaken on the 170MI/d and 205MI/d options to determine if any surge suppression measures are required to protect the pipeline. The surge analysis has analyzed the system

The key findings from the analysis are as follows:

- 7.14.2 **Roddy Lane Pumping Station (PS1)** - A DN600 or similar bypass and NRV is proposed for Roddy Lane PS. No additional surge mitigation measures are likely to be required at this site.
- 7.14.3 **Cottenham Pumping Station (PS2)** - A one-way surge vessel at Yew Tree Farm will maintain positive pressure in the pipeline, but possibly less than the target +5 metres. A tank or tanks of total volume of 280 m³ (or less) is likely to be suitable. With further consideration it may be possible to protect the pipeline with suitable anti-shock air valves at Yew Tree Farm. A DN600 bypass is necessary at the pumping station.
- 7.14.4 **Drenewydd Pumping Station (PS3)** - The optimal surge protection for Drenewydd PS is a 41 m³ suction side surge vessel and a 36 m³ delivery side surge vessel. A pump station bypass is not required.

7.15

7.15.1

7.15.2

Table 11 - Raw Water Aqueduct Flow rates for 170Ml/d trade

De-chlorination Plant

- 7.15.19 Preliminary process design work has been undertaken on sizing a de-chlorination plant. The design has been based on using sodium thiosulphate for de-chlorination. The dosing will require careful control as sodium thiosulphate can be quite harmful to river eco systems. To get EA approval for the system we will have to demonstrate that the system is suitably robust for continuous operation over a long period to ensure the river is protected from chlorine, whilst also having fail-safe measures to prevent overdosing of thiosulphate.
- 7.15.20 The system proposed will have two-point thiosulphate dosing, a primary dose and a residual trim after the buffer tank. Raw water will be blended into the dosed water in the buffer tank which will help to dilute any residual chlorine or surplus sodium thiosulphate.
- 7.15.21 A final trim dose can be added if required post buffer tank. The flows will then be released in the bypass pipeline that discharges into the River Severn. The discharge pipeline provides an additional buffer volume.
- 7.15.22 The process calculations and Block Process Diagram have been used to determine storage and dosing requirements.
- 7.15.23 The key equipment required is summarised below:
- Mag Flow Meter & Chamber
 - Sample Pumps & Cl2 Analyzers (Triple)
 - Thiosulphate Bulk Storage (9m3)
 - Thiosulphate Dosing Pumps
 - Static Mixer and POA
 - Buffer Tank (1.1Ml) & Chemical Delivery facilities
 - Sample Pumps & Cl2 Analyzers (Double)
 - Static Mixer and POA
 - Sample Pumps & Cl2 Analyzers (Double)
 - Turbidity Monitors (Double)
 - PH Monitors (Double)
- 7.15.24 A location for the de-chlorination plant has been identified on land adjacent to the south . United Utilities own the land, and the route of the proposed bypass / discharge pipeline terminates in this area.
- 7.15.25 A preliminary layout is included in the diagram below:

Figure 37 -

Hydraulic Design and Interface with WTW Improvement Project

- 7.15.26 There are a number of issues affecting the design that will require further work during the next phase. This is because the two projects will have to be delivered on site simultaneously. It is likely that the scope for VA Water Trading will be delivered by the AMP7 contractor. As a result, some form of integration of the design teams will be necessary.
- 7.15.27 At this stage in the lifecycle of the two projects, it has only been possible to develop an outline design that will need to be integrated into the AMP7 contract. However, the following key hydraulic parameters must be met:
- The final combined design must maintain a minimum of 5m head at the inlet to the Vyrnwy Aqueduct.
 - Must be able to pass from the outlet of the Floc Sed tanks to the bypass tank.
 - The final design must prevent backflow from the break pressure tank to the clear water tanks.
 - Further hydraulic design is required to ensure that the break pressure tank is adequately sized.
 - A hydraulic profile which combines the scope for the two projects will need to be developed.
- 7.15.28 There are also several areas where a combined solution will need to be developed as follows:
- Finding bypass pipe routes through the site to be demolished and redeveloped. Currently the size and positions of the new structures have not been finalized.
 - A combined strategy for Start Up to Waste and de-chlorination needs to be developed for the two projects.
 - A combined PFD, Control Philosophy and P&ID will need to be developed.
 -
 -
 -
 - A Design Approval process will need to be agreed between the projects.

- The work undertaken to date has shown that it is possible to produce a design at WTW that will meet the needs of the VA Water Trading project. However, before a more detailed solution can be prepared, the design will need to be developed in tandem with the WTW Improvements project.

Interface with River Vyrnwy Bypass Pipeline (STW SRO).

- 7.15.29 The River Vyrnwy Bypass Pipeline scheme takes the trade water and conveys it to the River Severn. This pipeline will need to be able to receive the full range of trade flows. It will also be left to stand empty for long periods and must be capable of self-priming when the trade is required and flows are turned.
- 7.15.30 The location of the interface between WTW and the pipeline has been agreed for the Gate 2 conceptual design.

7.16 Summary

7.16.1 The Options identified in the Gate 1 CDR report have been investigated and developed then presented in this report. The work undertaken demonstrates that for two trade flow scenarios – up to 170MI/d and up to 205 MI/d, there are options that can be engineered to work. The SRO requirement is for a 205MI/d trade option, the 170MI/d trade is presented as an opportunity to achieve a trade at a significant reduced capex cost. The scope needed for 205MI/d is the same as for the 170MI/d between Norton Tower and Malpas BPT, but a third pumping station and associated lining works is needed, in addition to the Shrewsbury redeployment scope.

7.16.2 A summary of the engineering required for each of the two options is given below:

- **The 170MI/d Option (opportunity)**
-
- The remaining Cast-Iron pipework at Valve Houses and Valve Chambers and Bulk Supply Points will be renewed as part of a separate VA Water Trading project.
- A remote monitoring and control system will be installed for managing the aqueduct. This will require all new valve chambers and valve houses to have actuated valves. New power supplies and comms links will be needed for all the sites.
-
-
- **The 205MI/d Option**

-
-
- The remaining Cast-Iron pipework at Valve Houses and Valve Chambers and Bulk Supply Points will be renewed as part of a separate VA Water Trading project.
- A remote monitoring and control system will be installed for managing the aqueduct. This will require all new valve chambers and valve houses to have actuated valves. New power supplies and comms links will be needed for all the sites.
-
-

8. Water Trading Enabling Works

8.1 Vyrnwy Aqueduct Modernisation Programme (cleaning and lining)

8.1.1 The VAMP Project which involves cleaning and lining will deliver a significant proportion of the work required for the VA Water Trading project through the relining of lines 1 and 2 between Malpas and Norton Tower. The first of three contracts under the project (Malpas to Cotebrook) is about to be awarded, with the second and third contracts due out for tender in 2023. However, the project scope does not include for renewing the valve chamber and valve house pipework which must be replaced for the VA Water Trading scheme.

8.1.2 Because of the overlapping scope, the project team were asked to identify if there were any opportunities to deliver any scope collaboratively across the two projects. This was driven by a number of issues:

- (1) The landowners and third parties are common across the two projects. The work could take up to ten years to complete, but there may be ways to significantly reduce the disruption they will face.
- (2) Working collaboratively across the two projects may offer opportunities for significant time and cost savings.
- (3) Working collaboratively may reduce the outage requirements on the aqueduct, hence reducing the operational risks associated with outages on the aqueduct.

8.1.3 The collaborative opportunities were only considered on the proviso that they do not put the VA Cleaning & Lining Project output date of December 2028 at risk.

8.1.4 If any suitable opportunities were found, it was agreed that funding could be sought from RAPID.

Options for Undertaking the Work

8.1.5 There are two siphon sections of Vyrnwy Aqueduct between Malpas and Norton Tower that are common to both projects. Three potential options for completing the VA Water Trading scope were identified in these sections as follows:

- (1) Wait until the completion of the lining project in 2028 and then carrying out the VA Water Trading work;
- (2) Replacing crossovers in situ during the lining project (See below);

Figure 38 - Proposed Crossover Replacement Works during Vyrnwy Cleaning and Lining Works

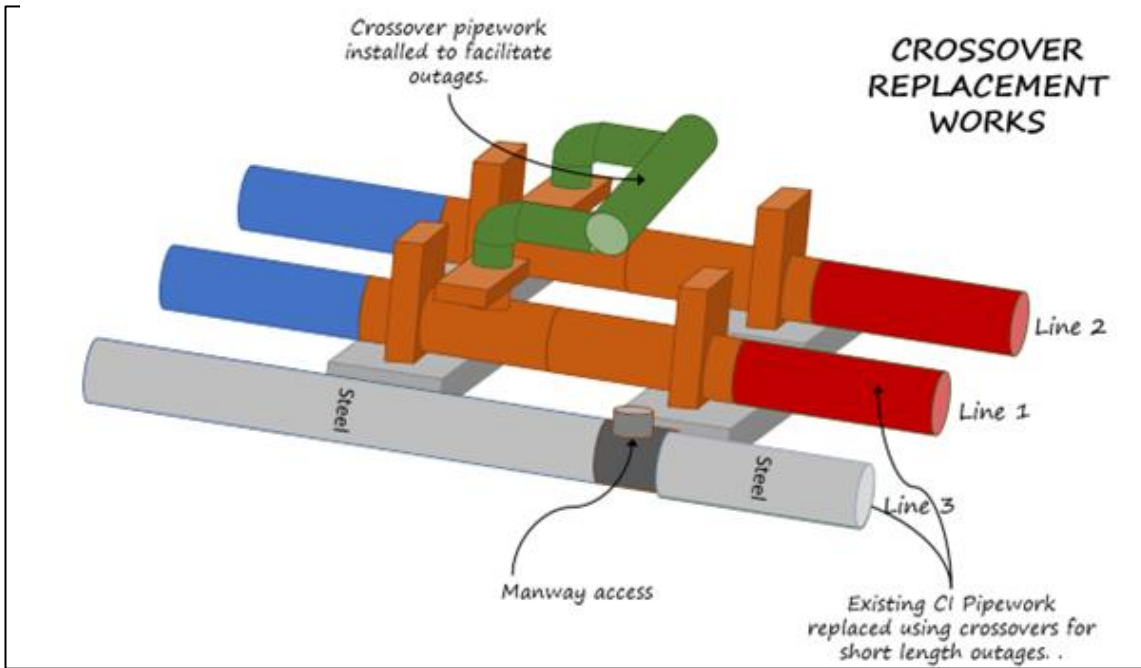

Install t-pieces during the lining project and replace crossovers offline later.

Figure 39 - Proposed Crossover Enabling Works during Vyrnwy Cleaning and Lining Works

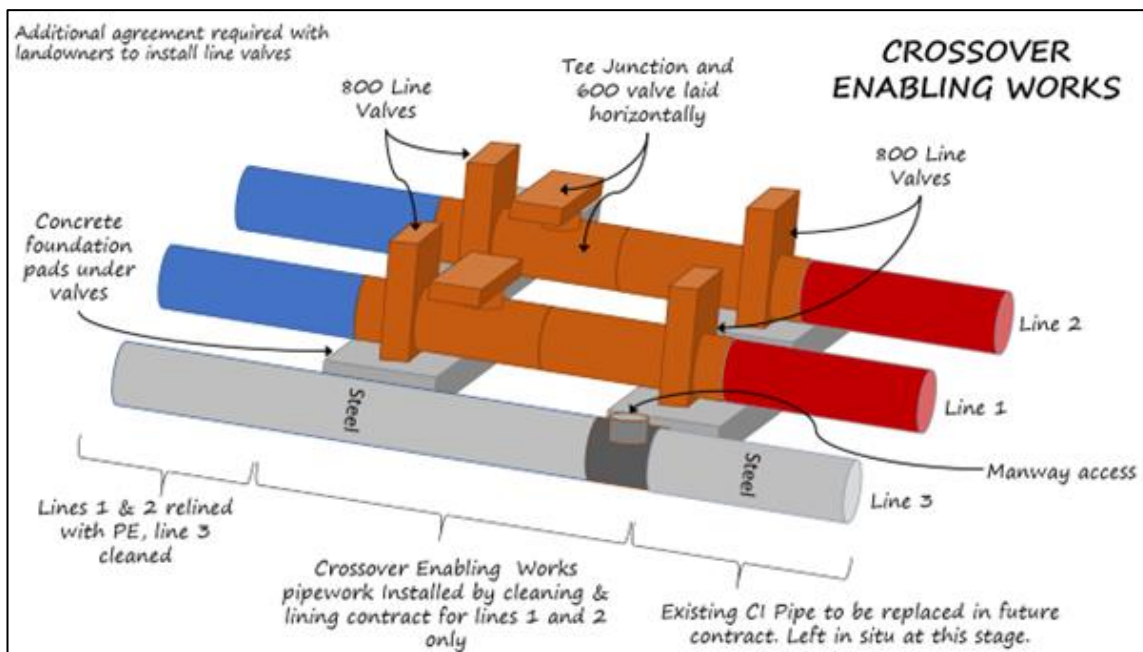

8.1.6 The impacts of the options have been considered separately for Siphon 1 (Malpas to Cotebrook) and Siphon 2 (Cotebrook to Norton Tower) because they are in different stages of development. Siphon 1 contract is about to be awarded, whereas Siphon 2 is still in pre-tender development.

Siphon 1 – Malpas to Cotebrook (Contract 1)

8.1.7 This siphon section is included in Contract 1 of the Vyrnwy Lining project. There are 5 valve-houses or crossovers that would need to be renewed in order to facilitate the VA Water Trading scope as shown below.

Figure 40 - Cleaning and Lining (Contract 1) – Malpas to Cotebrook Crossover Enabling Works**Options review – Siphon 1**

8.1.8 Table 12 below summarises the impact of the different options on regulatory dates, stakeholders, resilience and cost. Because the contract award process for Contract 1 is already in progress, there is a risk of significant changes to scope related to option 2 causing delay and stakeholder disruption. **Therefore, it is recommended that option 3 be progressed for Contract 1**

Table 12 - Siphon 1 Options review

Option	Description	DWI Date Impact	Stakeholder Impact	Resilience impact*	Cost Savings due to Collaborative working
1	Replace crossovers in situ after lining project	DWI date achieved	4 years disruption to stakeholders with return visits for NWT	Additional combined 4 years outage	£0 savings due to working collaboratively
2	Replace crossovers in situ during lining project	DWI Legal Notice December 2028 at risk	Would need to change existing Stakeholder agreements.	4 year reduction in outage	Estimated cost saving = £3.2m
3	Water Trading enabling works during lining project and Secondary visit to complete offline	DWI date achieved	Some additional Stakeholder disruption from Phase 2 visit for crossover off-line construction	reduction to short outages only	Estimated Cost Saving = £1.7m

*Other outages may be required to deliver other trading enabling works beyond 2028

Siphon 2 – Cotebrook to Norton Tower (Contract 2)

8.1.9 This section is covered in Contract 2 of the Vyrnwy Lining project, which will go out to tender next year. There are 4 valve-houses or crossovers that would need to be addressed in order to facilitate water trading as shown below.

Figure 41 - Cleaning and Lining (Contract 2) – Cotebrook to Norton Crossover Enabling Works

Options review – Siphon 2

8.1.10 Table 13 below summarises the impact of the different options on regulatory dates, stakeholders, resilience and cost. We are yet to go out to tender for Contract 2 and therefore there is time to define the detailed requirements for each of the 4 locations for inclusion in the tender documentation without putting the delivery date at risk. *For these reasons it is recommended that option 2 be progressed for Contract 2*

Table 13 - Siphon 2 Options review

Option	Description	DWI Date Impact	Reputational Impact	Resilience impact*	Overall Cost impact
1	Replace crossovers in situ after lining project	DWI date achieved	4 yrs additional disruption	additional combined 4 yrs outage	£0 savings due to working collaboratively
2	Replace crossovers in situ during lining project	DWI date achieved	Low – avoids prolonged disruption	4yr reduction in outage	Estimated Cost Saving = £2.7m
3	Water Trading enabling works during lining project and Secondary visit to complete offline	DWI date achieved	Some additional Stakeholder disruption from Phase 2 visit for crossover off-line construction	reduction to short outages only	Estimated Cost Saving = £1.7m

*Other outages may be required to deliver other trading enabling works beyond 2028

BENEFITS & RISKS

8.1.11 As a result of this assessment, it was recommended that for Siphon 1 Option 3, and for Siphon 2 Option 2 be carried forward. The benefits and risks are set out below.

Benefits:

- Overall reduction in capital costs due to collaborative working of £4.4m
- Approximately £1M/year of additional operating cost avoidance due to the increased availability of Oswestry (maximising benefits of AMP7 investment in that asset).
- Reduction in local stakeholder disruption by approximately 3 years
- Significant reduction in outages on siphon 1 phase 2 due to the short lengths of pipe to be upgraded.

- Improvement to overall health for a critical asset
- Accelerated delivery of trading capability supporting overall water supply resilience in England.

Risks:

- Delay to full completion of the Vyrnwy lining project - this risk is low and can be mitigated through the sectional management of project scope through the delivery phase. Priority will be given to successful completion of the lining with trading enabling works following on each section.
- Investing ahead of final commercial agreements for trading - we would need to seek approval to use AMP7 trading funding for Siphon 1 and a PR24 enhancement case for Siphon 2. If not accepted the trading work would not proceed in AMP8.

8.1.12 A Paper has been submitted to RAPID making the recommendations outlined above. It will be discussed at the next meetings, but at this point in time, the outcome is not yet known.

8.2

8.2.1 New pipework is required to be installed to transfer flow from the WTW to the River during a trade scenario. There are two connection points considered for this option, the first is a new connection downstream of the 1st Stage Filters, the second is from the outlet of the new AMP8 clear water tanks. From these two connections points, new pipework is required to transfer the flow to the New BPT. There is an opportunity to accelerate the detailed design for these connections and add them to the scope of the WTW project to prevent more difficult construction activities and disruption of treatment flows should they be implemented post the main construction works.

9. Constructability Review

9.1 Vyrnwy Aqueduct

9.1.1 The scope of construction work is typical for large utility/infrastructure projects and shall consist of the following typical activities:

- Working on or adjacent to 'live' potable water aqueducts
 - Water hygiene practices
 -
 - Health and Safety
- Excavations in and around existing utility services (Security of Supply)
- Construction of potable water pumping stations (Based on UU Signature design/asset standards)
 - Civil groundworks/excavations/foundations
 - Reinforced concrete slabs
 - Installation of below ground ducting systems for building services
 - Steel portal frame erection
 - Blockwork/bricklaying
 - Roof installation working at height
 - Large diameter pipework installation
 - Mechanical pump and valve installation
 - Steel fabrication and welding
 - HV and LV Electrical installation
 - Control panel installation and wiring
 - Connections and installation of valves into large diameter potable trunk mains
 - Temporary accommodation works such as access roads, protection slabs, hedge and dry-stone wall removal
 - Slip lining using fusion bonded PE structural liner pipe
 - New power supplies
 - Installation of telecommunications both above and below ground cabling

9.1.2 As a result, it is anticipated that the construction methodologies employed will be typical for the water sector.

9.1.3 The existing aqueducts are particularly sensitive due to their material, age and condition and nature of the jointing technique used when they were originally constructed, namely lead run joints. It is imperative that water quality is not compromised as a result of any construction activity, such as vibration, which could result in mobilisation of settled sediment causing turbidity spikes resulting in discoloration and taste issues for customers.

9.1.4 Any movement of the aqueducts could cause a leak at joints or burst in the pipe section. Employment of hand excavation and vacuum excavation techniques are likely to be needed, along with special consideration of sheet piling techniques around the aqueducts following extensive site investigation work to confirm depth, joint location, diameter, bed and surround detail.

- 9.1.5 The new pumping stations shall be positioned at ground level on slab foundation, they shall be located in close proximity to the existing aqueducts to minimize the suction and delivery pipe lengths. Ground investigation shall be undertaken to determine the foundation detail.
- 9.1.6 Where existing cast iron pipework and valves are to be replaced at valve chamber and valve house locations, local excavation and temporary support systems and techniques shall be employed to prevent disturbance and ground movement to adjacent pipework and structures.
- 9.1.7 Working on and around live potable water mains is business as usual but the best water hygiene methods and practices shall be adopted to prevent contamination risk.

Construction of New Pumping Stations on the Vyrnwy Aqueduct for 205 MI/d Trade

- 9.1.8 For the 205 MI/d trade scenario, three new pumping stations are required on the Vyrnwy Aqueduct
- 9.1.9 A Constructability Review has been carried out for each of the new pumping station locations to determine a suitable construction method whilst maintaining flow in the aqueduct.
- 9.1.10 The detailed scope and construction sequence is to be developed during Gate 3 on a site-by-site basis, however a conceptual generic scope of works and sequence has been developed during the Gate 2 process.
- 9.1.11 The new pumping stations on Sections B and C will pump up Lines The new pumping station on Section A will use Line with the rising main section of the steel pipework back towards WTW
- 9.1.12 For the new pumping stations in Sections B and C the aim will be to create a by-pass on Line from which the new pump set pipework will be built off with the abandoned section of Line being removed. This will allow the new pump set pipework for Line to be constructed within this space.
- 9.1.13 Figure 27 and Figure 28 in this report show a typical schematic detail of the new pumping stations in Section B and C and how they will operate during normal gravity operation (Figure 27) and during water trading (Figure 28).
- 9.1.14 An opportunity exists to install the new pipework during the Cleaning and Lining Project (Vyrnwy Aqueduct Maintenance Programme) whilst the aqueduct is on low flows which will involve the new by-pass pipework for Line 2 with new valved Tee pieces and valves for the suction and delivery pipework's and similar for new Tee pieces and valves on Line 2.
- 9.1.15 The remaining pump station pipework can be completed at a later date without the need for any outages on the Vyrnwy Aqueduct.
- 9.1.16 The new pumping station in Section A will require isolation and shutdown of Line 3 for the installation of the pump set pipework.
- 9.1.17 The pumping stations shall be constructed in accordance with the asset standard requirements and signature design details, it is envisaged that shallow raft foundations are likely however should a piled foundation be required, low vibration plant and techniques can be adopted to prevent disturbance to the live aqueducts.
- 9.1.18 A small crane is envisaged to be required for construction of the pumping station pipework, valves and superstructure, and protection measures shall be installed to prevent any transfer of load from plant onto the existing aqueducts.
- 9.1.19 The use of excavators and proprietary trench support systems will be employed for installation of below ground pipework and ducting for buried services.

Crossover Enabling Works / Vyrnwy Aqueduct Maintenance Programme (VAMP)

9.1.20

9.1.21 Due to time constraints on the VAMP Programme, all Valve Chambers / Houses are not being lined due to the nature and complexity of removing and replacing the existing assets at these sites. See Figures 8 and 9 in Section 2.3.2 for Valve Chamber / House details.

9.1.22 An opportunity exists to install additional extra valves between the insert PE Liner and the existing CI pipework

Pipework and Valve Replacement at Valve Chambers and Valve Houses

9.1.23 Replacement of the existing CI pipework, valves, air valves and washouts at each of the Valve Chambers and Valve House locations will require separate shutdowns of each line in turn) with the existing assets being removed and new ductile pipework, new isolation valves, new air valves and new washouts being installed on a like for like basis. The inclusion of additional valves on the VAMP Project for the Crossover Enabling Works Project (see above) will significantly reduce the lengths of each line taken out to enable this scope of works to be carried out during the NWT – VA Project.

Dee Aqueduct to Vyrnwy Aqueduct Cross Connection

9.1.24

9.2

9.2.1

9.2.2 Under maximum flow trading conditions, all flow from these sources will blend within the New BPT prior to de-chlorination before transfer to the new River By-Pass Pipeline for discharge into the River Vyrnwy or Severn (to be confirmed).

9.2.3 The connection points onto existing pipework will present some challenges due to depth and congested nature of the area whilst maintaining flow through the treatment works. Temporary works shall require careful consideration and sequencing of excavation and installation will need to be coordinated with the main WTW construction.

9.2.4 The new de-chlorination facility is shown to land south of the existing site boundary, during the detailed design phase it may be possible to integrate this facility within the existing WTW site boundary and also combine the installation with the start up to waste facility, but for a concept solution this arrangement represents a worst-case envelope. The chemical receipt, storage and dosing facility required to treat the water prior to discharge into the river Vyrnwy bypass pipeline, shall meet current UU asset standards and signature design layout arrangements, this type of facility is typical for a treatment works and poses no constructability issues from the norm.

- 9.2.5 Both teams will be working collaboratively on the final connection points and pipe routing required for NWT – VA Project throughout Gate 3.
- 9.2.6 It is envisaged that multiple contracts may be necessary to deliver all the works associated with implementation of the transfer scope, the procurement strategy shall be developed through Gate 3 and Gate 4.

10. Risk and Opportunity

- 10.1.1 The risk is managed at a Project level using the Northwest Transfer Project risk register dated July 2022. The risk items are reviewed on a monthly basis and top risks discussed at weekly progress meetings. Risk owners are assigned and a mitigation plan identified to manage the risk going forward.
- 10.1.2 The risks shall continue to be reviewed and where possible mitigated as the solution is developed through the gated lifecycle.
- 10.1.3 The key risks are listed below:

Table 14 - Risks

- 10.1.4 Risk and Value workshops (R&V1 & 1a) were held on 14th March 22 and 29th April 22.

11. Environmental Assessment

- 11.1.1 The enabling works have been subject to environmental assessment undertaken during Gate 2, which has built on the initial environmental assessment work undertaken at Gate 1 and has comprised:
- An Invasive Non-Native Species Assessment to identify risks and mitigations to avoid the transfer of such species.
 - Informal assessments of compliance with the Water Framework Directive and Habitats Directive, intended to inform the formal compliance assessments that will be required at Gate 3 to inform planning and permit applications.
 - Biodiversity Net Gain Assessments to ensure the implementation of the sub-options provides at least the minimum required 10% increase in biodiversity, and to identify strategic opportunities for the implementation of this.
 - A Natural Capital Assessment to support identification of the best value solution and decision making
 - Preparation of an IEA Report, which pulls together the above assessments into a combined environmental appraisal for the NWT sub-options and solution.
- 11.1.2 Our Gate 2 assessments have been undertaken following methodologies established in consultation with the NAU and NRW, and aligned with the assessment methodologies for WRMP24 and the WRW Regional Plan. The conceptual design of the sub-options for G2 has taken into account the early findings of these assessments. During the early phases of Gate 3 the design of the enabling works will be progressed, taking into account the findings of the above environmental assessment to remove or mitigate any significant environmental impacts identified.
- 11.1.3 For further information please refer to section 6 of the main Gate 2 Report.

12. Town & Country Planning Assessment

- 12.1.1 Much of the scope of work, such as connection points, replacement of crossover chambers and valve houses etc. would be covered by UU's permitted development rights as a statutory water undertaker. Planning permission for these aspects would only be required if the size of any building structure was to increase to over 29 m³ in volume or if new accesses were required for construction or operation of the assets.
- 12.1.2 The relining work, as a maintenance activity on an existing pipeline, does not constitute development and is currently being progressed by the project team. The only aspects requiring planning approval for this are associated with construction accesses and remote compounds.
- 12.1.3 Planning permission will be required for the 3 new pumping stations and, as currently designed, the de-chlorination plant
- 12.1.4 Beyond Gate 2 all necessary survey work to support planning applications will take place along with stakeholder engagement and public consultation where required. Great Crested newts are known to be present . This survey and consultation work will inform the detailed siting and design of the additional assets and ultimately support the planning (and any other consent) applications to be submitted post Gate 3.
- 12.1.5 For further information please refer to section 6 of the main Gate 2 Report

13. Programme

13.1.1 Please refer to Section 7 of the Gate 2 main report

14. Further Work

- 14.1.1 As part of the Gate 3 and Gate 4 detailed design activities, the following is a non-exhaustive list of further activities and/or deliverables which shall be required to be completed within the course of the detailed design phase.
- Design of VA Water Trading Enabling Works
 - Raw Water Aqueduct Mains – Condition Survey and remediation scope
 - Water Quality Modelling
 - Network HAZOP / Criticality Options
 - Continued Development of Systems Thinking Scope of Work
 - Detailed Design Network Modelling
 - Design Development (De-chlorination plant, balance tank etc)
 - detailed hydraulic design
 - Liaison with River Vyrnwy Bypass Pipeline Contract (STT)
 - Design of Valve Chambers, Valve Houses & Bulk Supply Points
 - Pumping Station Design
 - Computational Dynamic Flow Survey of existing Break Pressure Tanks during Water Trading operation.
 - Review location of proposed pumping stations and select suitable locations that take into account - hydraulics, access, residential issues, environmental, geotechnical and ecology issues.
 - Topographical survey and trial holes for proposed connection points to the Vyrnwy Aqueduct to determine condition, size, and levels of existing pipework.
 - Ground investigation scoping to provide soil parameters for detailed design of permanent and temporary works
 - Integration with the Vyrnwy Cleaning and Lining Programme for Section C to assist and reduce outage periods on Vyrnwy Aqueduct (opportunity for cost savings).
 - Develop method for constructing offline pumping stations to Vyrnwy Aqueduct whilst maintaining minimum flow and coordinate with Vyrnwy Aqueduct Cleaning and Lining Team to reduce number of outages required.
 - Surge Suppression Design (including Dee aqueduct pumping)
 - Land Purchase (Pumping Stations & possibly at some valve chamber locations)
 - Third Party and landowner negotiations
 - Environmental Studies
 - Planning Applications
 - Power Supply Applications
 - Telecoms Applications

15. Conclusion

- 15.1.1 The NWT SRO can enable a range of transfer volumes up to a maximum of 205M l/d in conjunction with UU Sources works. It is recommended that the 205Ml/d option is progressed to Gate 3 for further consideration. During Gate 3 this option will be assessed, modelled and designed in more detail (outline design) to reduce uncertainty, clarify assumptions and mitigate risks in the development of more robust scopes, costs and prices for water transfer. Gate 3 will conclude with the submission to planning application and thus the option shall be developed enough enable planning approval.
- 15.1.2 There are sufficient water sources in the North West to compensate for a transfer of up to 205 Ml/d based on the utilisation figures modelled in the water resources modelling whilst maintaining treatment production capacity and resilience to the network.
- 15.1.3 Further network modelling, site investigation and survey work as outlined in section 14 is recommended as part of Gate 3 investigations.

16. Glossary

Acronym:	Explanation:
RAPID	Regulators Alliance for Progressing Infrastructure Development
DWI	Department for Water Inspectorate
NWT	North West Transfer
PR24	Price Review 2024
SRO	Strategic Resource Option
AMP	Asset Management Plan
UU	United Utilities
R&V	Risk and Value
STT	Severn Trent Transfer
CDR	Conceptual Design Report
MI/d	Million litres Per day
l/s	Litres Per Second
mAOD	Meters Above Ordnance Datum
WTW	Water Treatment Works
SR	Service Reservoir
RGF	Rapid Gravity Filters
SUTW	Start Up To Waste
UV	Ultraviolet Treatment
GAC	Granular Activated Carbon
PS	Pumping Station
BSP	Bulk Supply Points
CS	Concessionary Supplies
VA	Vyrnwy Aqueduct
RWA	Raw Water Vyrnwy Aqueduct
BPT	Break Pressure Tank
AV	Air Valve
WO	Washout Facility
PE	Polyethylene Pipe
CI	Cast Iron Pipework
ST	Steel Pipework
ST	Systems Thinking
TWL	Top Water Level (in mAOD)
BWL	Bottom Water Level (in mAOD)
CT	Contact Tank
CWT	Clear Water Tank
VH	Valve Houses
VC	Valve Chambers
P&ID	Process and Instrumentation Diagram
BAU	Business as Usual
NRV	Non-Return Valve
EWI	Employers Works Information
HAZOP	Hazards in Operation
ALM	Access, Lifting and Maintenance
PBD	Process Block Diagrams
WBS	Work Breakdown Structure
VAMP	Vyrnwy Aqueduct Modernisation Programme (Cleaning and lining project)

United Utilities Water Limited
Haweswater House
Lingley Mere Business Park
Lingley Green Avenue
Great Sankey
Warrington
WA5 3LP
unitedutilities.com



Water for the North West